

INSTRUCTION WEEK OF MAY 18TH 2020

MS. KELLY'S SIXTH GRADE GLOBAL THINKERS

**i'm always
with you**



STUDENT OF THE WEEK:

- STUDENT OF THE WEEK FOR THE WEEK OF MAY 11TH 2020: **DARWIN** FOR HIS EXCEPTIONAL EFFORT EVEN WHEN TRAVELING TO ANOTHER STATE! TALK ABOUT DEDICATION!
- STUDENT OF THE WEEK FOR THE WEEK OF MAY 4TH 2020: **BRYAN** FOR ALWAYS ATTENDING ZOOM EVEN WITH ONLY HAVING ACCESS TO A CELL PHONE AND SUBMITTING WORK ALL WEEK. HOPEFULLY YOU CAN GET SOMETHING WITH A SCREEN SOON!
- STUDENT OF THE WEEK FOR APRIL 27TH 2020: **SAMANTA!** FOR ALWAYS ATTENDING ZOOM SESSIONS AND WORKING HARD TO SUBMIT WORK EACH DAY LAST WEEK!
- STUDENT OF THE WEEK **MARIO!** VERY PROUD OF YOUR DEDICATION TO ZOOM SESSIONS AND SUBMITTING WORK!
- NEW STUDENT OF THE WEEK FOR APRIL 13TH 2020: **KENIA** FOR SUBMITTING ALL WORK AND ALWAYS ATTENDING ZOOM SESSIONS ON TIME!
- NEW STUDENTS OF THE WEEK FOR THE WEEK OF APRIL 6TH 2020: **ANGEL AND JACQUELINE** THEIR WORK HAS BEEN AMAZING!!!!
- NEW STUDENTS OF THE WEEK FOR MARCH 30TH: KEVIN AND JAKE. STUDENTS OF THE WEEK FOR MARCH 23RD: **KENIA, DARWIN, AND ZEYDI.**

Knowledge is
POWER

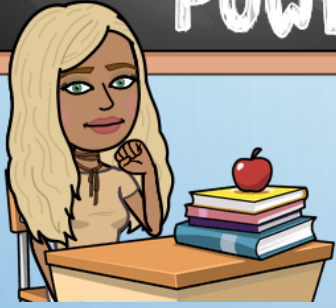

MORNING MESSAGE:

- GOOD MORNING! TODAY IS MONDAY MAY 18TH 2020. WE WILL HAVE MUSIC TODAY AT 10:40 A.M. WITH MR. DELLA-RATTA!
- THANK YOU TO THOSE STUDENTS FOR SUBMITTING WORK OVER THE WEEKEND: JACQUELINE, DARWIN, KENIA, KEVIN, ANGIE, ANGEL, JERRY AND MICHAEL.
- **MRS. PEREZ WILL FACILITATE A PARENT MEETING TODAY, MONDAY, MAY 18TH AT 1:30PM. SHE WILL PRESENT TIPS TO SUPPORT PARENTS WITH DISTANCE LEARNING. PLEASE INVITE YOUR PARENTS.**
 - **MEETING ID: 746 6535 9049**
 - **PASSWORD: 2KTYJB**
- TODAY IS A NEW WEEK! WE WILL ONLY HAVE ONLINE TEACHER CONTACT MONDAY THROUGH THURSDAY THIS WEEK. WE WILL BE OFF FOR MEMORIAL DAY WEEKEND FRIDAY, MONDAY, AND TUESDAY. A PROJECT WILL BE ASSIGNED.
- THIS WEEK WE WILL:

WE WILL BE READING, "RESCUING OUR DOCUMENTS OF FREEDOM" IN OUR RALLY READING BOOK THIS WEEK.

IN MATH WE WILL BE CONTINUING THROUGH MODULE 13 AREA AND POLYGONS AND WORKING ON RALLY BOOK LESSON 28.

IN SCIENCE WE WILL BE WORKING IN OUR MEASURING UP BOOKS ON LESSON 42: ECOSYSTEMS AND ENVIRONMENTAL CHANGES.

IN SOCIAL STUDIES WE WILL CONTINUE READING "ANCIENT CHINA" FOUND ON OUR SCHOLASTIC APP.

Barack Obama Elementary School

May 19th & May 21st



1st, 2nd & 3RD Grade
Tuesday @ 2:30

4th, 5th & 6th Grade
Thursday @ 2:30



Zoom Log In

413 204 394

*Your Teacher Will Give You The
Password*

Monday Morning Meeting:

What do you see, think, see, and wonder about the image below?



RALLY BOOK READING ASSIGNMENT: “RESCUING OUR DOCUMENTS OF FREEDOM” (PAGE 207-209)

- **LESSON: CRAFT AND STRUCTURE**
- **STANDARD: RI.6.5** ANALYZE HOW A PARTICULAR SENTENCE, PARAGRAPH, CHAPTER, OR SECTION FITS INTO THE OVERALL STRUCTURE OF A TEXT AND CONTRIBUTES TO THE DEVELOPMENT OF THE IDEAS.
- **OBJECTIVE:** I CAN ANALYZE VARIOUS SECTIONS OF THE TEXT TO DETERMINE HOW THEY HELP DEVELOP THE BIG IDEA OF THE ENTIRE TEXT.
- **ENTRY TICKET:** AS AN AUTHOR YOU WANT TO MAKE YOUR MESSAGE CLEAR, WHAT CAN YOU DO TO MAKE SURE YOUR READER UNDERSTANDS YOUR MESSAGE?

RALLY BOOK READING ASSIGNMENT: “RESCUING OUR DOCUMENTS OF FREEDOM.”

- BEFORE READING, LET’S ANALYZE THE DIFFERENT TEXT FEATURES AND HOW THEY ARE USED TO HELP DEVELOP A LARGER IDEA.

1.SIDE-BAR: PROTECTING THE PAST

2.

3.

RALLY BOOK READING ASSIGNMENT: "RESCUING OUR DOCUMENTS OF FREEDOM."

Rescuing Our Documents of Freedom

By Sharlene P. Nelson

- 1 In the summer of 1814, Stephen Pleasonton served as a senior clerk for Secretary of State James Monroe. Pleasonton worked with other clerks in the State Department offices in Washington City, the nation's young capital. Eight thousand people lived in the city where new government buildings stood along dirt streets.
- 2 These were the final days of the War of 1812, when United States soldiers and sailors defended the nation against the British. Some people thought the British might attack Washington. Others thought the city was safe, including Secretary of War John Armstrong. He declared, "... they certainly will not come here! What the devil will they do here?" The British, however, intended to capture Washington. Admiral George Cockburn said that taking a country's capital is "always so great a blow to the government of a country."
- 3 Messages began arriving in Washington saying that the British were coming. James Monroe volunteered to scout their movement. He mounted his horse and rode nearly fifty miles southeast of the city. On Saturday, August 20, Monroe spied the British commanded by Admiral Cockburn. He watched their ships sailing up the Patuxent River in Maryland and their troops marching overland toward Washington.
- 4 Monroe quickly scribbled a note to Pleasonton and gave it to a messenger. As the messenger rode into Washington, dust clouds filled the hot, humid air. Horses and oxen pulled wagons filled

Protecting the Past

Every year more than a million people visit the National Archives in Washington, D.C. They come to see the Declaration of Independence and the U.S. Constitution. Signed more than two hundred years ago, the documents are sealed behind thick glass, where visitors can see the faded signatures of our Founding Fathers. After the



documents were signed, the U.S. Congress placed them in the care of the State Department.

with the household goods of people fleeing the city. The messenger hurried through the crowd, found Pleasonton, and gave him the note.

5 Pleasonton read Monroe's note. It ordered him to find a safe place for the Declaration of Independence and the Constitution. "I proceeded to purchase coarse linen and cause it to be made into bags of convenient size," Pleasonton later wrote. He, with the other clerks, began placing department records, George Washington's letters, the Declaration of Independence, and the Constitution in the linen bags. As they worked, Secretary of War John Armstrong walked by on the way to his office.

6 His voice rising in anger, Armstrong told Pleasonton he was foolish. Armstrong still believed the British would not attack Washington. "I replied that we were under a different belief," wrote Pleasonton, "... it was the part of prudence to preserve the valuable papers of the Revolutionary Government." He finished packing, then loaded the valuable cargo onto carts.

7 Pleasonton and other clerks drove the horse-drawn carts across a Potomac River bridge and continued upriver a few miles to an abandoned mill. Pleasonton hid the linen bags in the mill. Then he changed his mind. He noticed that the mill was near a foundry where cannons were made. He was afraid that the British might find the foundry and destroy it, the mill, and the valuable documents.

8 The next day, Pleasonton obtained wagons from nearby farmers. After loading the linen bags into the wagons, he and the men drove thirty-five miles to Leesburg, Virginia. They arrived on the evening of August 24. Pleasonton found an empty house, stored the documents, locked the doors, and gave the key to the sheriff. Exhausted, Pleasonton checked into a hotel. That night while he slept, Leesburg townspeople watched a distant, bright glow in the night sky. The British had set fire to Washington. Homes and government buildings were burned, including the State Department offices.

The Constitution

The thirteen American colonies wanted to be free and independent of Great Britain. In 1776, representatives from the colonies signed the Declaration of Independence declaring their freedom. After winning freedom in the American Revolution, representatives created and signed the U.S. Constitution. In 1789, the Constitution became the law for the new nation of the United States of America.



9 A month later, the United States defeated the British at Baltimore, Maryland. People began returning to Washington to rebuild the city. The Declaration of Independence and the Constitution were also returned to the capital.

10 In 1820, Stephen Pleasonton was appointed superintendent of the nation's lighthouse establishment, a position he held for thirty-two years. Many remember him as the superintendent who established more than 260 U.S. lighthouses. Few remember him as the clerk who rescued our documents of freedom.

RALLY BOOK READING ASSIGNMENT: “RESCUING OUR DOCUMENTS OF FREEDOM” (PAGE 207-209)

- **LESSON: CRAFT AND STRUCTURE**
- **STANDARD: RI.6.5** ANALYZE HOW A PARTICULAR SENTENCE, PARAGRAPH, CHAPTER, OR SECTION FITS INTO THE OVERALL STRUCTURE OF A TEXT AND CONTRIBUTES TO THE DEVELOPMENT OF THE IDEAS.
- **OBJECTIVE:** I CAN ANALYZE VARIOUS SECTIONS OF THE TEXT TO DETERMINE HOW THEY HELP DEVELOP THE BIG IDEA OF THE ENTIRE TEXT.
- **ENTRY TICKET:** WHAT PARTICULAR SENTENCE, PARAGRAPH, OR SECTION CONTRIBUTES TO A LARGER IDEA IN THE TEXT, “RESCUING OUR DOCUMENTS OF FREEDOM?”

UNIT 6: RELATIONSHIPS IN GEOMETRY

MODULE 13: AREA AND POLYGONS

- **LESSON:** AREA OF POLYGONS
- **STANDARD:** **6.G.A.1** FIND THE AREA OF RIGHT TRIANGLES, OTHER TRIANGLES, SPECIAL QUADRILATERALS, AND POLYGONS BY COMPOSING INTO RECTANGLES OR DECOMPOSING INTO TRIANGLES AND OTHER SHAPES.
- **OBJECTIVE:** I CAN FIND THE AREA OF PARALLELOGRAMS, RHOMBUSES, AND TRAPEZOIDS.
- **ENTRY TICKET:**

5. Find the area of the parallelogram.

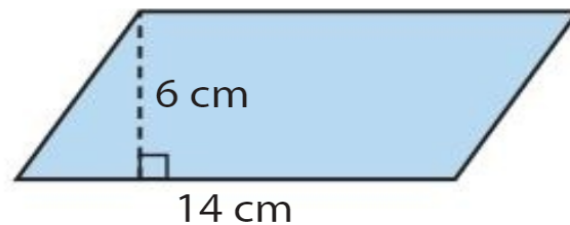

RALLY BOOK PAGE 78 QUESTION 3

- THREE BIKE RIDERS RECORDED THEIR DISTANCES AND TIMES AS SHOWN IN THE TABLE BELOW:

Rider	Distance (d)	Times (t)
Lauren	24 miles	180 minutes
Melody	31 $\frac{1}{2}$ miles	3 $\frac{1}{2}$ hours
Sean	29.75 miles	210 minutes

USE THE FORMULA $D=RT$ TO FIND EACH RIDER'S RATE IN MILES PER HOUR. THEN, PUT THREE RIDERS' SPEEDS IN ORDER FROM SLOWEST TO FASTEST.

GO MATH ONLINE STUDENT BOOK

- STUDENTS WILL COMPLETE MODULE 13 LESSON 1 BY FOLLOWING ALONG ONLINE WITH THE STUDENT ONLINE WORK BOOK AND THEIR MATH NOTEBOOK.

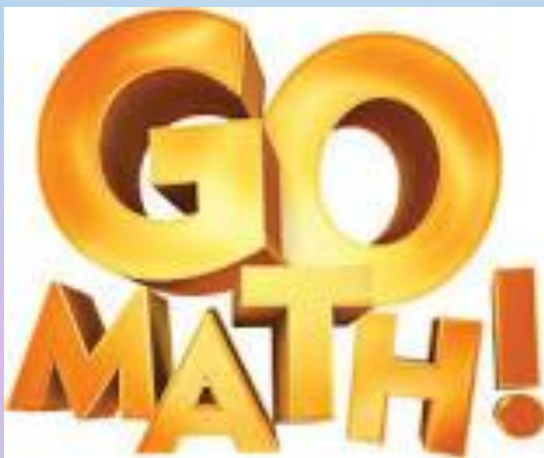

WORK DUE MONDAY

MAY 18TH 2020

- **READING: RALLY BOOK READING**, “RESCUING OUR DOCUMENTS OF FREEDOM.” (PAGES 207-209) READ, ANNOTATE, AND ANSWER MULTIPLE CHOICE QUESTIONS 1-7
- **MATH: RALLY BOOK MATH** LESSON 28. READ THE INSTRUCTIONAL PAGES 191-197. ANSWER MULTIPLE CHOICE QUESTION 5 . EXPLAIN YOUR THINKING AND PROCESS.
- **SCIENCE: MEASURING UP BOOK** LESSON 42: ECOSYSTEMS AND ENVIRONMENTAL CHANGES(PAGES 267-271) READ, ANNOTATE, AND ANSWER THE GUIDED QUESTIONS.
- **SOCIAL STUDIES: SCHOLASTIC APP**: READ THE TEXT “ANCIENT CHINA.” ANSWER THE FOLLOWING QUESTIONS BASED ON CHAPTER 3 “A LAND OF PLENTY”: (PAGE 38-40)
 1. WHAT INFORMATION DID YOU LEARN ABOUT MODERN CHINA?
 2. HOW DID THE YELLOW RIVER GET ITS NAME?
 3. WHY IS THE YELLOW RIVER SO SIGNIFICANT?

STUDENT OF THE WEEK:

- STUDENT OF THE WEEK FOR THE WEEK OF MAY 11TH 2020: **ANGIE** FOR SUBMITTING ALL WORK DUE LAST WEEK! WHAT AN IMPROVEMENT!
- STUDENT OF THE WEEK FOR THE WEEK OF MAY 4TH 2020: **BRYAN** FOR ALWAYS ATTENDING ZOOM EVEN WITH ONLY HAVING ACCESS TO A CELL PHONE AND SUBMITTING WORK ALL WEEK. HOPEFULLY YOU CAN GET SOMETHING WITH A SCREEN SOON!
- STUDENT OF THE WEEK FOR APRIL 27TH 2020: **SAMANTA!** FOR ALWAYS ATTENDING ZOOM SESSIONS AND WORKING HARD TO SUBMIT WORK EACH DAY LAST WEEK!
- STUDENT OF THE WEEK **MARIO!** VERY PROUD OF YOUR DEDICATION TO ZOOM SESSIONS AND SUBMITTING WORK!
- NEW STUDENT OF THE WEEK FOR APRIL 13TH 2020: **KENIA** FOR SUBMITTING ALL WORK AND ALWAYS ATTENDING ZOOM SESSIONS ON TIME!
- NEW STUDENTS OF THE WEEK FOR THE WEEK OF APRIL 6TH 2020: **ANGEL AND JACQUELINE** THEIR WORK HAS BEEN AMAZING!!!!
- NEW STUDENTS OF THE WEEK FOR MARCH 30TH: KEVIN AND JAKE. STUDENTS OF THE WEEK FOR MARCH 23RD: **KENIA, DARWIN, AND ZEYDI.**

Knowledge is
POWER

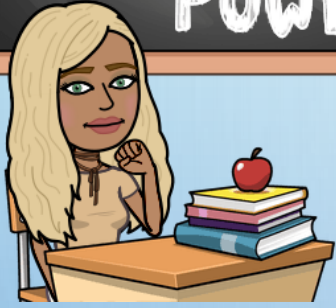

MORNING MESSAGE:

- GOOD MORNING! TODAY IS TUESDAY MAY 19TH 2020. WE WILL HAVE ART TODAY AT 10:40 A.M. WITH MS. CHESTER!
- SCHOOL DANCE THURSDAY VIA ZOOM! WHAT IS YOUR OPINION ON SUCH EVENTS?
- REMINDER WE WILL NOT HAVE ONLINE INSTRUCTION FRIDAY, MONDAY, AND TUESDAY FOR MEMORIAL DAY WEEKEND.
- THIS WEEK WE WILL:

WE WILL BE READING, "RESCUING OUR DOCUMENTS OF FREEDOM" IN OUR RALLY READING BOOK THIS WEEK.

IN MATH WE WILL BE CONTINUING THROUGH MODULE 13 AREA AND POLYGONS AND WORKING ON RALLY BOOK LESSON 28.

IN SCIENCE WE WILL BE WORKING IN OUR MEASURING UP BOOKS ON LESSON 42: ECOSYSTEMS AND ENVIRONMENTAL CHANGES.

IN SOCIAL STUDIES WE WILL CONTINUE READING "ANCIENT CHINA" FOUND ON OUR SCHOLASTIC APP.

Barack Obama Elementary School

May 19th & May 21st



1st, 2nd & 3RD Grade
Tuesday @ 2:30

4th, 5th & 6th Grade
Thursday @ 2:30



Zoom Log In

413 204 394

*Your Teacher Will Give You The
Password*

Tuesday Morning Meeting:

Are you proud of your progress for the fourth quarter? Is your online learning successful? Could you continue this type of learning long term?



RALLY BOOK READING ASSIGNMENT: “RESCUING OUR DOCUMENTS OF FREEDOM” (PAGE 207-209)

- **LESSON: CRAFT AND STRUCTURE**
- **STANDARD: RI.6.5** ANALYZE HOW A PARTICULAR SENTENCE, PARAGRAPH, CHAPTER, OR SECTION FITS INTO THE OVERALL STRUCTURE OF A TEXT AND CONTRIBUTES TO THE DEVELOPMENT OF THE IDEAS.
- **OBJECTIVE:** I CAN ANALYZE VARIOUS SECTIONS OF THE TEXT TO DETERMINE HOW THEY HELP DEVELOP THE BIG IDEA OF THE ENTIRE TEXT.
- **ENTRY TICKET:** WHAT WAS HAPPENING IN THE EARLY 1800’S IN AMERICA BASED ON PAGE 207?

RALLY BOOK READING ASSIGNMENT: "RESCUING OUR DOCUMENTS OF FREEDOM."

- ❖ What is the overall purpose of the side bar?
- ❖ How does it contribute to our overall understanding of the text?

Rescuing Our Documents of Freedom

By Sharlene P. Nelson

- 1 In the summer of 1814, Stephen Pleasonton served as a senior clerk for Secretary of State James Monroe. Pleasonton worked with other clerks in the State Department offices in Washington City, the nation's young capital. Eight thousand people lived in the city where new government buildings stood along dirt streets.
- 2 These were the final days of the War of 1812, when United States soldiers and sailors defended the nation against the British. Some people thought the British might attack Washington. Others thought the city was safe, including Secretary of War John Armstrong. He declared, "... they certainly will not come here! What the devil will they do here?" The British, however, intended to capture Washington. Admiral George Cockburn said that taking a country's capital is "always so great a blow to the government of a country."
- 3 Messages began arriving in Washington saying that the British were coming. James Monroe volunteered to scout their movement. He mounted his horse and rode nearly fifty miles southeast of the city. On Saturday, August 20, Monroe spied the British commanded by Admiral Cockburn. He watched their ships sailing up the Patuxent River in Maryland and their troops marching overland toward Washington.
- 4 Monroe quickly scribbled a note to Pleasonton and gave it to a messenger. As the messenger rode into Washington, dust clouds filled the hot, humid air. Horses and oxen pulled wagons filled

Protecting the Past

Every year more than a million people visit the National Archives in Washington, D.C. They come to see the Declaration of Independence and the U.S. Constitution. Signed more than two hundred years ago, the documents are sealed behind thick glass, where visitors can see the faded signatures of our Founding Fathers. After the



documents were signed, the U.S. Congress placed them in the care of the State Department.

with the household goods of people fleeing the city. The messenger hurried through the crowd, found Pleasonton, and gave him the note.

5 Pleasonton read Monroe's note. It ordered him to find a safe place for the Declaration of Independence and the Constitution. "I proceeded to purchase coarse linen and cause it to be made into bags of convenient size," Pleasonton later wrote. He, with the other clerks, began placing department records, George Washington's letters, the Declaration of Independence, and the Constitution in the linen bags. As they worked, Secretary of War John Armstrong walked by on the way to his office.

6 His voice rising in anger, Armstrong told Pleasonton he was foolish. Armstrong still believed the British would not attack Washington. "I replied that we were under a different belief," wrote Pleasonton, "... it was the part of prudence to preserve the valuable papers of the Revolutionary Government." He finished packing, then loaded the valuable cargo onto carts.

7 Pleasonton and other clerks drove the horse-drawn carts across a Potomac River bridge and continued upriver a few miles to an abandoned mill. Pleasonton hid the linen bags in the mill. Then he changed his mind. He noticed that the mill was near a foundry where cannons were made. He was afraid that the British might find the foundry and destroy it, the mill, and the valuable documents.

8 The next day, Pleasonton obtained wagons from nearby farmers. After loading the linen bags into the wagons, he and the men drove thirty-five miles to Leesburg, Virginia. They arrived on the evening of August 24. Pleasonton found an empty house, stored the documents, locked the doors, and gave the key to the sheriff. Exhausted, Pleasonton checked into a hotel. That night while he slept, Leesburg townspeople watched a distant, bright glow in the night sky. The British had set fire to Washington. Homes and government buildings were burned, including the State Department offices.

The Constitution

The thirteen American colonies wanted to be free and independent of Great Britain. In 1776, representatives from the colonies signed the Declaration of Independence declaring their freedom. After winning freedom in the American Revolution, representatives created and signed the U.S. Constitution. In 1789, the Constitution became the law for the new nation of the United States of America.



9 A month later, the United States defeated the British at Baltimore, Maryland. People began returning to Washington to rebuild the city. The Declaration of Independence and the Constitution were also returned to the capital.

10 In 1820, Stephen Pleasonton was appointed superintendent of the nation's lighthouse establishment, a position he held for thirty-two years. Many remember him as the superintendent who established more than 260 U.S. lighthouses. Few remember him as the clerk who rescued our documents of freedom.

RALLY BOOK READING ASSIGNMENT: “RESCUING OUR DOCUMENTS OF FREEDOM” (PAGE 207-209)

- **LESSON: CRAFT AND STRUCTURE**
- **STANDARD: RI.6.5** ANALYZE HOW A PARTICULAR SENTENCE, PARAGRAPH, CHAPTER, OR SECTION FITS INTO THE OVERALL STRUCTURE OF A TEXT AND CONTRIBUTES TO THE DEVELOPMENT OF THE IDEAS.
- **OBJECTIVE:** I CAN ANALYZE VARIOUS SECTIONS OF THE TEXT TO DETERMINE HOW THEY HELP DEVELOP THE BIG IDEA OF THE ENTIRE TEXT.
- **ENTRY TICKET:** WHAT PARTICULAR SENTENCE, PARAGRAPH, OR SECTION CONTRIBUTES TO A LARGER IDEA IN THE TEXT, “RESCUING OUR DOCUMENTS OF FREEDOM?”

UNIT 6: RELATIONSHIPS IN GEOMETRY

MODULE 13: AREA AND POLYGONS

- **LESSON:** AREA OF POLYGONS
- **STANDARD:** **6.G.A.1** FIND THE AREA OF RIGHT TRIANGLES, OTHER TRIANGLES, SPECIAL QUADRILATERALS, AND POLYGONS BY COMPOSING INTO RECTANGLES OR DECOMPOSING INTO TRIANGLES AND OTHER SHAPES.
- **OBJECTIVE:** I CAN FIND THE AREA OF PARALLELOGRAMS, RHOMBUSES, AND TRAPEZOIDS.
- **ENTRY TICKET:**

6. What is the area of a parallelogram that has a base of $12\frac{3}{4}$ in. and a height of $2\frac{1}{2}$ in.?

RALLY BOOK PAGE 197 QUESTION 5

WHAT VALUE OF Y IS THE SOLUTION TO THE EQUATION
 $4Y=28$?

AREA FORMULAS

Parallelogram:

Area = base x height



Rectangle/Square:

Area = Length x Width



Rhombus:

Area = $\frac{1}{2} d_1 d_2$



Triangle:

Area = $\frac{1}{2}bh$

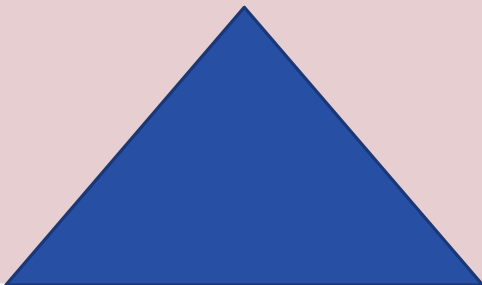

Trapezoid:

Area = $\frac{1}{2} h (b_1 + b_2)$

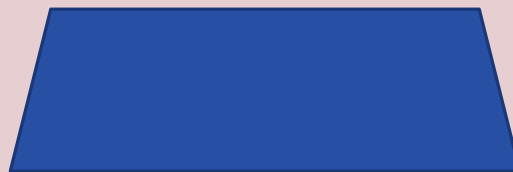

Overall conclusion:

All shapes are different, requiring different area formulas.

GO MATH ONLINE STUDENT BOOK

- STUDENTS WILL COMPLETE MODULE 13 LESSON 1 BY FOLLOWING ALONG ONLINE WITH THE STUDENT ONLINE WORK BOOK AND THEIR MATH NOTEBOOK.



WORK DUE TUESDAY

MAY 19TH 2020

- **READING: RALLY BOOK READING**, “RESCUING OUR DOCUMENTS OF FREEDOM.” (PAGES 207-209) READ, ANNOTATE, AND ANSWER SHORT RESPONSE QUESTION 8
- **MATH: RALLY BOOK MATH** LESSON 28. READ THE INSTRUCTIONAL PAGES 191-197. ANSWER MULTIPLE CHOICE QUESTION 6 . EXPLAIN YOUR THINKING AND PROCESS.
- **SCIENCE: MEASURING UP BOOK** LESSON 42: ECOSYSTEMS AND ENVIRONMENTAL CHANGES(PAGES 267-271) READ, ANNOTATE, AND ANSWER QUESTIONS 1 AND 2 PAGE 269.
- **SOCIAL STUDIES: SCHOLASTIC APP**: READ THE TEXT “ANCIENT CHINA.” ANSWER THE FOLLOWING QUESTIONS BASED ON CHAPTER 3 “FINDING THE WAY” : (PAGE 41)
 1. WHAT INVENTION DID THEY CREATE DURING THE WARRING STATE?
 2. HOW DOES THE INVENTION WORK?
 3. WHAT DID THEY ORIGINALLY USE IT FOR?



Knowledge is
POWER

MORNING MESSAGE:

- GOOD MORNING! TODAY IS WEDNESDAY MAY 20TH 2020. WE WILL HAVE MEDIA TODAY AT 10:40 A.M. WITH MS. RANDAZZO! WHAT IS DUE TODAY??
- SCHOOL DANCE THURSDAY VIA ZOOM! PASSWORD: 049311
- MRS. FAIRCLOUGH IS OFFERING \$100 DOLLARS TO A STUDENT ON EACH GRADE WHO IS LOGGING ON IREADY EVERYDAY AND COMPLETING ONE MATH AND ONE READING LESSON SUCCESSFULLY. WHO IS UP FOR THE CHALLENGE?
- REMINDER WE WILL NOT HAVE ONLINE INSTRUCTION FRIDAY, MONDAY, AND TUESDAY FOR MEMORIAL DAY WEEKEND.
- THIS WEEK WE WILL:

WE WILL BE ANALYZING, “RESCUING OUR DOCUMENTS OF FREEDOM” IN OUR RALLY READING BOOK THIS WEEK.

IN MATH WE WILL BE CONTINUING THROUGH MODULE 13 AREA AND POLYGONS AND WORKING ON RALLY BOOK LESSON 28.

IN SCIENCE WE WILL BE WORKING IN OUR MEASURING UP BOOKS ON LESSON 42: ECOSYSTEMS AND ENVIRONMENTAL CHANGES.

IN SOCIAL STUDIES WE WILL CONTINUE READING “ANCIENT CHINA” FOUND ON OUR SCHOLASTIC APP.

Barack Obama Elementary School

May 19th & May 21st



1st, 2nd & 3RD Grade
Tuesday @ 2:30

4th, 5th & 6th Grade
Thursday @ 2:30



Zoom Log In

413 204 394

*Your Teacher Will Give You The
Password*

RALLY BOOK READING ASSIGNMENT: “RESCUING OUR DOCUMENTS OF FREEDOM” (PAGE 207-209)

- **LESSON: CRAFT AND STRUCTURE**
- **STANDARD: RI.6.5** ANALYZE HOW A PARTICULAR SENTENCE, PARAGRAPH, CHAPTER, OR SECTION FITS INTO THE OVERALL STRUCTURE OF A TEXT AND CONTRIBUTES TO THE DEVELOPMENT OF THE IDEAS.
- **OBJECTIVE:** I CAN ANALYZE VARIOUS SECTIONS OF THE TEXT TO DETERMINE HOW THEY HELP DEVELOP THE BIG IDEA OF THE ENTIRE TEXT.
- **ENTRY TICKET:** WHAT STRATEGIES ARE WE UTILIZING FOR MULTIPLE CHOICE ANSWERS? ARE THEY WORKING?

RALLY BOOK READING ASSIGNMENT: “RESCUING OUR DOCUMENTS OF FREEDOM” (PAGE 207-209)

QUESTION 2:

READ THESE SENTENCES ABOUT PLEASOTON FROM THE END OF THE ARTICLE:

“MANY REMEMBER HIM AS THE SUPERINTENDENT WHO ESTABLISHED MORE THAN 260 U.S. LIGHTHOUSES. FEW REMEMBER HIM AS THE CLERK WHO RESCUED OUR DOCUMENTS OF FREEDOM.”

THESE SENTENCES ARE MAINLY INCLUDED TO-

- a. SHOW THE PLEASONTON WAS REWARDED FOR HIS EFFORTS.
- b. SUGGEST THAT PLEASONTON IS AN UNSUNG HERO.
- c. REMIND READERS TO APPRECIATE VIEWING THE DECLARATION OF INDEPENDENCE.
- d. PERSUADE READERS TO BELIEVE THAT EVERY SINGLE PERSON CAN MAKE A DIFFERENCE.

RALLY BOOK READING ASSIGNMENT: “RESCUING OUR DOCUMENTS OF FREEDOM” (PAGE 207-209)

QUESTION 3:

WHY DID PLEASONTON BELIEVE IT WAS IMPORTANT TO PRESERVE THE GOVERNMENT DOCUMENTS?

CAN WE CREATE OUR OWN ANSWER BEFORE ANALYZING THE CHOICES?

RALLY BOOK READING ASSIGNMENT: “RESCUING OUR DOCUMENTS OF FREEDOM” (PAGE 207-209)

QUESTION 4:

HOW MIGHT THIS INFORMATION BE PRESENTED IN A DIFFERENT WAY IF IT WERE WRITTEN AS AN AUTOBIOGRAPHY?

ANALYZING SONG LYRICS

- LISTEN CLOSELY TO THE LYRICS! GET READY TO SHARE TO SHARE.

UNIT 6: RELATIONSHIPS IN GEOMETRY

MODULE 13: AREA AND POLYGONS

- **LESSON 2:** AREA OF TRIANGLES
- **STANDARD:** **6.G.A.1** FIND THE AREA OF RIGHT TRIANGLES, OTHER TRIANGLES, SPECIAL QUADRILATERALS, AND POLYGONS BY COMPOSING INTO RECTANGLES OR DECOMPOSING INTO TRIANGLES AND OTHER SHAPES.
- **OBJECTIVE:** I CAN FIND THE AREA OF TRIANGLES.
- **ENTRY TICKET:**

- 14. Communicate Mathematical Ideas** Find the area of the figure. Explain how you found your answer.

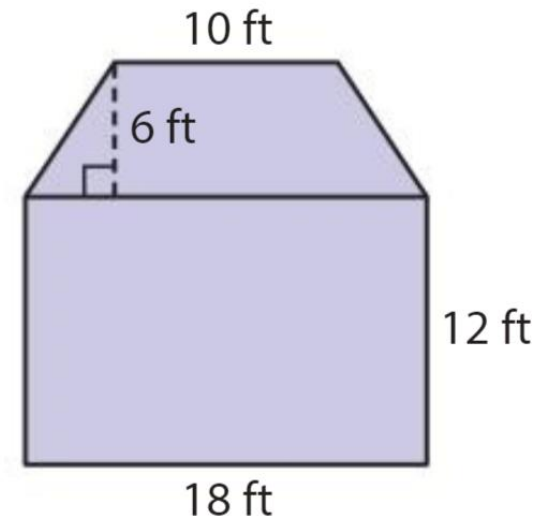

RALLY BOOK PAGE 197 QUESTION 6

WHAT VALUE OF R IS THE SOLUTION TO THE EQUATION

$$R + 9.62 = 24.29 ?$$

GO MATH ONLINE STUDENT BOOK

- STUDENTS WILL COMPLETE MODULE 13 LESSON 2 BY FOLLOWING ALONG ONLINE WITH THE STUDENT ONLINE WORK BOOK AND THEIR MATH NOTEBOOK.



WORK DUE WEDNESDAY MAY 20TH 2020

- **READING: RALLY BOOK READING**, “RESCUING OUR DOCUMENTS OF FREEDOM.” (PAGES 207-209) READ, ANNOTATE, AND ANSWER SHORT RESPONSE QUESTION 9.
- **MATH: RALLY BOOK MATH** LESSON 28. READ THE INSTRUCTIONAL PAGES 191-197. ANSWER MULTIPLE CHOICE QUESTION 7 . EXPLAIN YOUR THINKING AND PROCESS.
- **SCIENCE: MEASURING UP BOOK** LESSON 42: ECOSYSTEMS AND ENVIRONMENTAL CHANGES(PAGES 267-271) READ, ANNOTATE, AND ANSWER QUESTIONS 1-5 PAGE 270.
- **SOCIAL STUDIES: SCHOLASTIC APP**: READ THE TEXT “ANCIENT CHINA.” ANSWER THE FOLLOWING QUESTIONS BASED ON CHAPTER 3 “FARMING THE LAND”: (PAGE 42)
 1. HOW WAS THE CLIMATE IN THE NORTH?
 2. HOW WAS THE CLIMATE IN THE SOUTH?
 3. WHAT DID THEY STILL WORRY ABOUT AND WHY?

Knowledge is
POWER

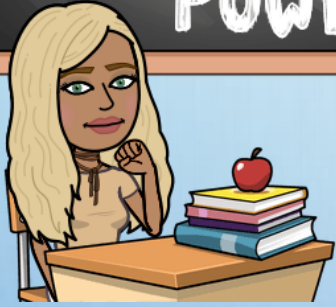

MORNING MESSAGE:

- GOOD MORNING! TODAY IS THURSDAY MAY 21ST, 2020. WE WILL HAVE GYM TODAY AT 10:40 A.M. WITH MR. JACOBS!
- SCHOOL DANCE TODAY VIA ZOOM! PASSWORD: 049311
- MRS. FAIRCLOUGH IS OFFERING \$100 DOLLARS TO A STUDENT ON EACH GRADE WHO IS LOGGING ON IREADY EVERYDAY AND COMPLETING ONE MATH AND ONE READING LESSON SUCCESSFULLY. WHO IS UP FOR THE CHALLENGE?
- REMINDER WE WILL NOT HAVE ONLINE INSTRUCTION FRIDAY, MONDAY, AND TUESDAY FOR MEMORIAL DAY WEEKEND.
- MS. KELLY WILL BE AT BARACK OBAMA AN UNABLE TO ZOOM FOR THE MORNING SESSION ON: WEDNESDAY MAY 27TH AND THURSDAY MAY 28TH. WE WILL ONLY HAVE AN AFTERNOON SESSION.
- THIS WEEK WE WILL:

WE WILL BE ANALYZING, "RESCUING OUR DOCUMENTS OF FREEDOM" IN OUR RALLY READING BOOK THIS WEEK.

IN MATH WE WILL BE CONTINUING THROUGH MODULE 13 AREA AND POLYGONS AND WORKING ON RALLY BOOK LESSON 28.

IN SCIENCE WE WILL BE WORKING IN OUR MEASURING UP BOOKS ON LESSON 42: ECOSYSTEMS AND ENVIRONMENTAL CHANGES.

IN SOCIAL STUDIES WE WILL CONTINUE READING "ANCIENT CHINA" FOUND ON OUR SCHOLASTIC APP.

ANALYZING SONG LYRICS

- LISTEN CLOSELY TO THE LYRICS! GET READY TO SHARE TO SHARE.

Arlington

by Trace Adkins

I never thought that this is where I'd settle down,
I thought I'd die an old man back in my hometown,
They gave me this plot of land,
me and some other men,
for a job well done.

There's a big white house sits on a hill just up the road.
The man inside he cried the day they brought me home,
They folded up a flag,
and told my mom and dad,
'We're proud of your son'.

And I'm proud to be on this peaceful piece of property,
I'm on sacred ground and I'm in the best of company,
I'm thankful for those thankful for the things I've done,
I can rest in peace,
I'm one of the chosen ones,
I made it to Arlington.

Analysis of 'Arlington'

After reading the first stanza, what can you infer about the narrator?

What is the 'big white house on a hill'?

Who is 'the man inside'?

What evidence in the second stanza shows that the narrator died young?

Find 2 examples of alliteration in the third stanza.

I remember Daddy brought me here when I was eight,
We searched all day to find out where my granddad lay,
And when we finally found that cross,
He said, 'Son this is what it cost,
to keep us free'.

Now here I am a thousand stones away from him,
He recognized me on the first day I came in,
And it gave me a chill,
when he clicked his heels,
and saluted me.

And I'm proud to be on this peaceful piece of property,
I'm on sacred ground and I'm in the best of company,
I'm thankful for those thankful for the things I've done,
I can rest in peace,
I'm one of the chosen ones,
I made it to Arlington.

And every time I hear twenty-one guns,
I know they brought another hero home, to us.
We're thankful for those thankful for the things
we've done,
We can rest in peace, 'cause we were the chosen ones,
We made it to Arlington,
yea, dust to dust
Don't cry for us,
we made it to Arlington.

Did the narrator's grandfather also die in war? How do you know?

The narrator says he is a "thousand stones away from" his grandfather. What do those thousand stones symbolize, or represent?

The narrator states "I'm in the best of company." What does this mean?

The narrator repeats "I made it to Arlington." What does this tell you about burials in Arlington Cemetery?

Memorial Day Lesson Pack

"Field of Honor" Viewing Guide

1. The first unknown (buried in the Tomb of the Unknown Soldier) died in battle in _____ and was interred in the tomb in the year _____.

2. Unidentified soldiers from three more wars were buried near the Tomb of the Unknown Soldier. Which wars?

3. Today, the tomb represents over _____ unknowns from all wars.

4. About how many funerals are held at Arlington National Cemetery each day? _____

5. What is the significance of a Caisson burial both past and present?

6. The property of the present-day Arlington Cemetery was once owned by _____

7. He built a memorial to honor former president _____ that is known as _____.

8. His daughter, Mary, married a young soldier named _____
Her husband would later become _____

9. An all-volunteer corps called the _____

keeps any family member from _____



10. The United States confiscated the Arlington House and sold it to _____ . It was used to bury _____ .

11. A _____ is a way to honor a pilot or air crewman.

12. By the end of the Civil War, over _____ dead were buried on the Arlington Estate.

13. Mary Custis Lee's son, Custis Lee, sued the US government and won the land back. Lee then sold the land back to the government for _____ .

14. Once considered a potter's field, the cemetery began to be seen as an honorable place after _____ sailors were buried there after the explosion and sinking of the _____ .

15. The cemetery's prestige continued to grow as _____ became the first US president to be buried there.

16. The most influential burial at Arlington Cemetery was President

17. This president was buried in the spot that he is reported to have said

_____.

18. The USCT, or the _____, were the first African Americans allowed into combat roles in the Civil War.

President _____ believed these men deserved citizenship.

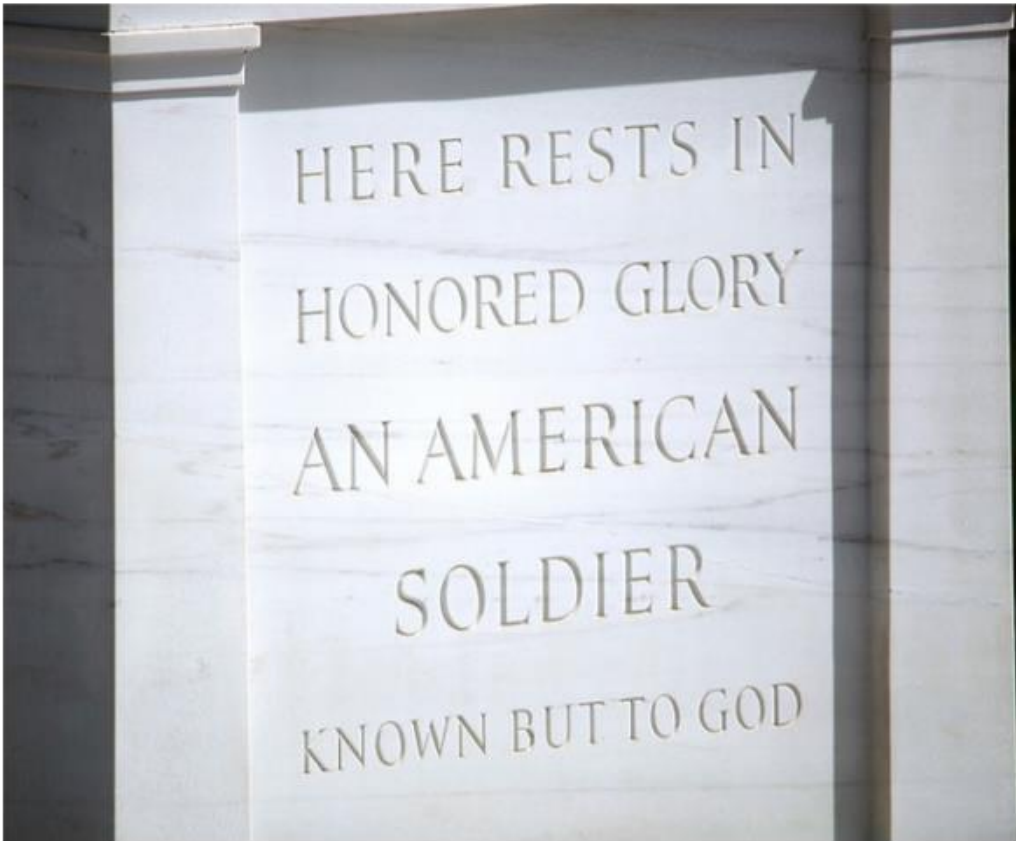

19. The ceremony that takes place each hour, half hour, or two hours, is known as the _____.

20. Today, Section _____ is reserved for soldiers who have been killed in Iraq and Afghanistan.

MEMORIAL DAY WEEKEND ASSIGNMENT

- WATCH, LISTEN, AND READ ALONG WITH THE FOLLOWING READ ALOUD:

[HTTPS://WWW.YOUTUBE.COM/WATCH?V=1WTXHZNERSE&FEATURE=Youtu.be](https://www.youtube.com/watch?v=1WTXHZNERSE&FEATURE=Youtu.be)

- WATCH THE FOLLOWING VIDEOS:

- [HTTPS://WWW.YOUTUBE.COM/WATCH?V=XWN2RPR-GHE](https://www.youtube.com/watch?v=XWN2RPR-GHE)

- [HTTPS://WWW.YOUTUBE.COM/WATCH?V=SGDG6CF2TPE](https://www.youtube.com/watch?v=SGDG6CF2TPE)

AFTER WATCHING THE APPROVE CLIPS COMPLETE THE FOLLOWING:

Memorial Day Quilt Squares

Memorial Day is celebrated in the U.S. to honor the soldiers who have died in the military to protect our country. Design a quilt square to remember and honor the brave men and women who fought and died for our freedoms. When they are all completed, we will put them together and make a class Memorial Day Remembrance Quilt.

What symbols, words, pictures, and graphics show the meaning of memorial day in your eyes?

UNIT 6: RELATIONSHIPS IN GEOMETRY

MODULE 13: AREA AND POLYGONS

- **LESSON 3:** SOLVING AREA EQUATIONS
- **STANDARD:** **6.G.A.1** FIND THE AREA OF RIGHT TRIANGLES, OTHER TRIANGLES, SPECIAL QUADRILATERALS, AND POLYGONS BY COMPOSING INTO RECTANGLES OR DECOMPOSING INTO TRIANGLES AND OTHER SHAPES.
- **OBJECTIVE:** I CAN USE AREA FORMULAS TO SOLVE FOR RECTANGLES, PARALLELOGRAMS, TRAPEZOIDS, AND TRIANGLES
- **ENTRY TICKET:**

12. Multistep The sixth-grade art students are making a mosaic using tiles in the shape of right triangles. Each tile has leg measures of 3 centimeters and 5 centimeters. If there are 200 tiles in the mosaic, what is the area of the mosaic?

RALLY BOOK PAGE 197 QUESTION 7

7. THERE ARE SOME CHILDREN AT A PARK. FIVE MORE CHILDREN COME TO THE PARK. THERE ARE NOW 17 CHILDREN IN THE PARK. WHICH EQUATION WILL FIND THE NUMBER OF CHILDREN, C , THAT WERE IN THE PARK ORIGINALLY?

a. $5 + 17 = C$

b. $C + 5 = 17$

c. $5C = 17$

d. $C - 5 = 17$

GO MATH ONLINE STUDENT BOOK

- STUDENTS WILL COMPLETE MODULE 13 LESSON 3 BY FOLLOWING ALONG ONLINE WITH THE STUDENT ONLINE WORK BOOK AND THEIR MATH NOTEBOOK.

